

# Mathematics test

## Paper 2

### Calculator allowed

Please read this page, but do not open your booklet until your teacher tells you to start. Write your name and the name of your school in the spaces below.

First name \_\_\_\_\_

Last name \_\_\_\_\_

School \_\_\_\_\_

#### Remember

- The test is 1 hour long.
- You may use a calculator for any question in this test.
- You will need: pen, pencil, rubber, ruler, a pair of compasses and a scientific or graphic calculator.
- Some formulae you might need are on page 2.
- This test starts with easier questions.
- Try to answer all the questions.
- Write all your answers and working on the test paper – do not use any rough paper. Marks may be awarded for working.
- Check your work carefully.
- Ask your teacher if you are not sure what to do.

For marker's  
use only

Total marks

Borderline check

## Instructions

### Answers



This means write down your answer or show your working and write down your answer.

### Calculators



You **may** use a calculator to answer any question in this test.

## Formulae

You might need to use these formulae

### Trapezium

$$\text{Area} = \frac{1}{2}(a + b)h$$

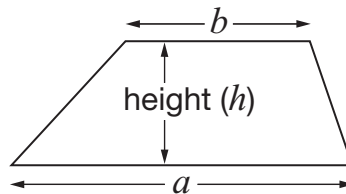

### Prism

area of cross-section

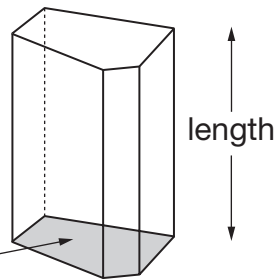

$$\text{Volume} = \text{area of cross-section} \times \text{length}$$

1. Look at the diagram, made from four straight lines.  
The lines marked with arrows are parallel.

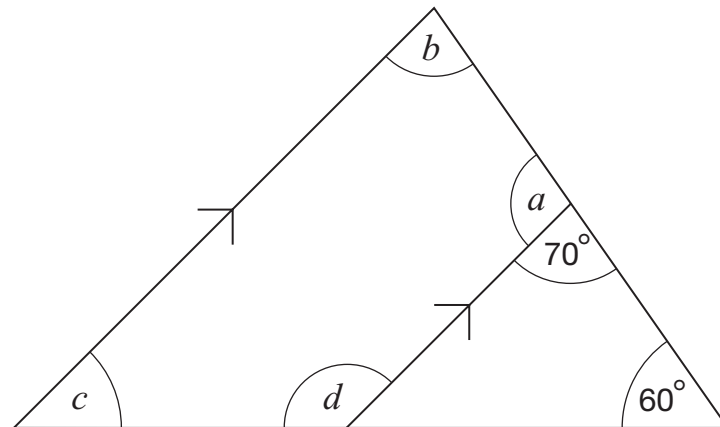

Not drawn  
accurately

Work out the sizes of the angles marked with letters.



$$a = \text{_____}^\circ$$

$$b = \text{_____}^\circ$$

$$c = \text{_____}^\circ$$

$$d = \text{_____}^\circ$$

3 marks



2. Look at this equation.

$$3a + 20 = 4a + k$$

- (a) If  $a = 15$ , find the value of  $k$

  $k =$  \_\_\_\_\_

\_\_\_\_\_ 1 mark



- (b) If  $a = -15$ , find the value of  $k$

  $k =$  \_\_\_\_\_

\_\_\_\_\_ 1 mark

3. Each shape below is made from **five cubes** that are joined together.

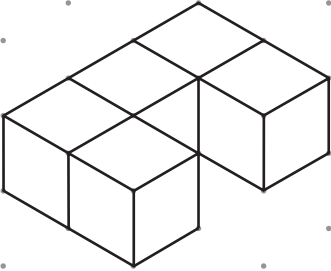
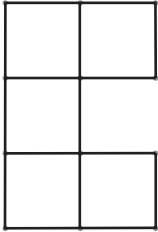
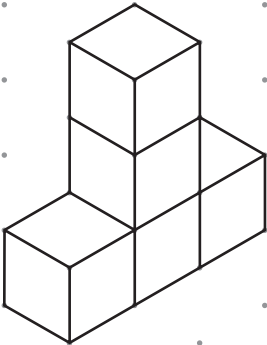
Complete the missing diagrams below.

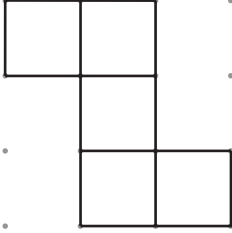
Shape drawn on an isometric grid	View from above of the shape drawn on a square grid
	
	
	

1 mark

2 marks



4. Look at these pairs of number sequences.

The second sequence is formed from the first sequence by adding a number or multiplying by a number.

Work out the missing  $n$ th terms.

(a) 5, 9, 13, 17, ...

$n$ th term is  $4n + 1$

6, 10, 14, 18, ...



$n$ th term is \_\_\_\_\_

1 mark

(b) 12, 18, 24, 30, ...

$n$ th term is  $6n + 6$

6, 9, 12, 15, ...



$n$ th term is \_\_\_\_\_

1 mark

(c) 2, 7, 12, 17, ...

$n$ th term is  $5n - 3$

4, 14, 24, 34, ...



$n$ th term is \_\_\_\_\_

1 mark

5. Look at the square grids.

Each diagram shows an enlargement of scale factor 2

The **centre** of this enlargement is marked with a cross.

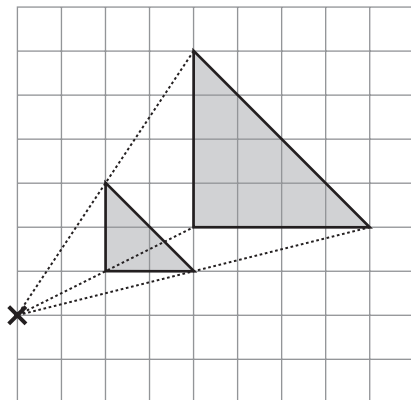

Where is the centre of enlargement in these diagrams?

Mark each one with a cross.

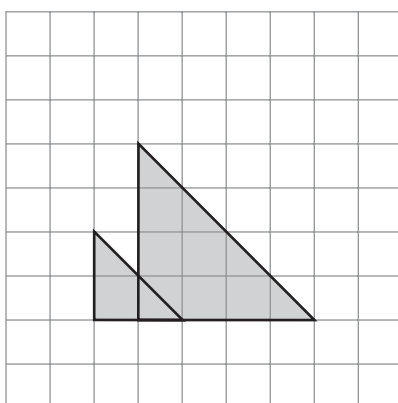

1 mark

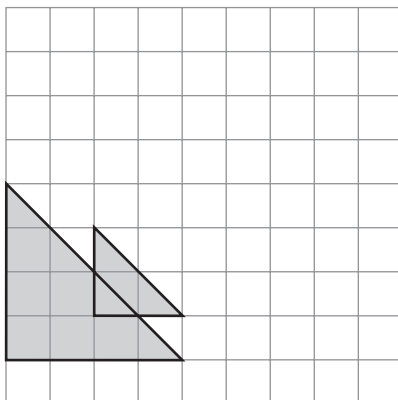

1 mark



6. Kate asked people if they read a daily newspaper.  
Then she wrote this table to show her results.

No	80 people = 40%
Yes	126 people = 60%

The values in the table **cannot** all be correct.

- (a) The error could be in the number of people.

Complete each table to show what the correct numbers could be.

No	80 people = 40%
Yes	_____ people = 60%

1 mark

No	_____ people = 40%
Yes	126 people = 60%

1 mark



---

(b) The error could be in the percentages.

Complete the table with the correct percentages.



No	80 people = _____ %
Yes	126 people = _____ %

\_\_\_\_\_  
\_\_\_\_\_  
2 marks



7. The graph shows information about the diameters and heights of a sample of three types of tomato.

The dotted lines on the graph can be used to decide which type of tomato each point is likely to represent.

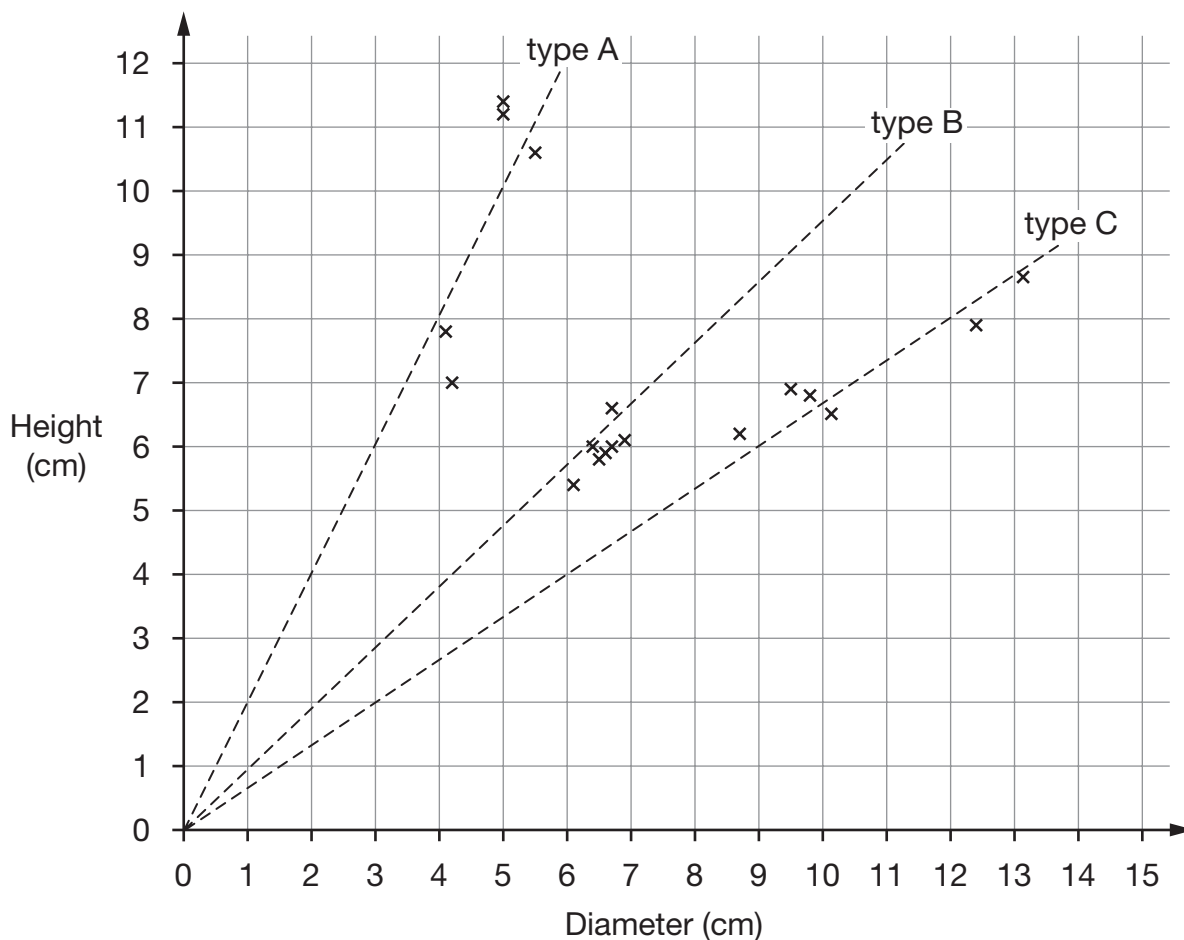
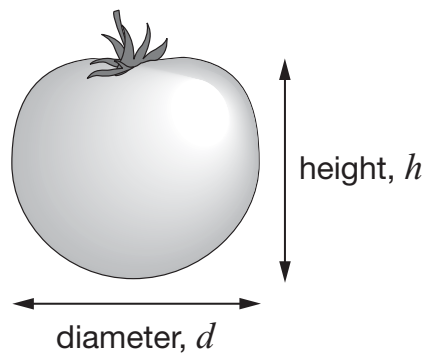

- (a) The diameter of a tomato of **type C** is **11 cm**.

What would you expect its height to be?



\_\_\_\_\_ cm

1 mark

(b) The diameter of a different tomato is 3.2cm. Its height is 5.8cm.

Which of the three types of tomato is it most likely to be?



A

B

C

Explain your answer.



1 mark

(c) Which type of tomato is most nearly **spherical** in shape?



A

B

C

Explain your answer.



1 mark

(d) You can find the approximate volume of a tomato by using this formula:

$$V = \frac{1}{6} \pi d^2 h$$

$V$  is the volume,  
 $d$  is the diameter,  
 $h$  is the height.

The diameter and the height of a tomato are both **3.5cm**.

What is the approximate volume of this tomato?



\_\_\_\_\_ cm<sup>3</sup>

2 marks



8. Multiply out these expressions.

Write your answers as simply as possible.

$$5(x + 2) + 3(7 + x)$$



---

---

2 marks

$$(x + 2)(x + 5)$$



---

---

2 marks

9. In a wildlife park in Africa, wardens want to know the position of an elephant in a certain area.

They place one microphone at each corner of a **4km by 4km** square.

Each microphone has a range of  $3\frac{1}{2}$  km.

The elephant is **out of range** of microphones **A** and **B**.

Where in the square could the elephant be?

Show the region **accurately** on the diagram, and **label** the region **R**.

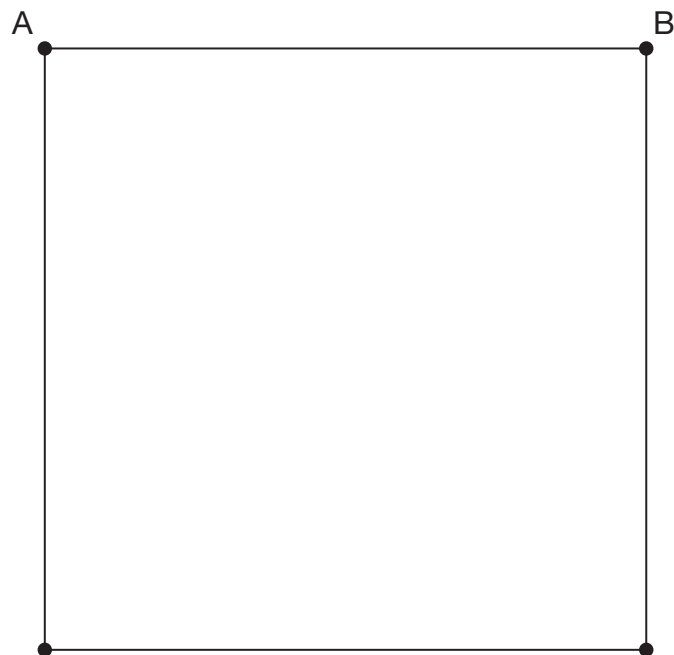

**Scale**  
2 cm to 1 km

\_\_\_\_\_  
\_\_\_\_\_  
2 marks



10. Here are the rules for an algebra grid.

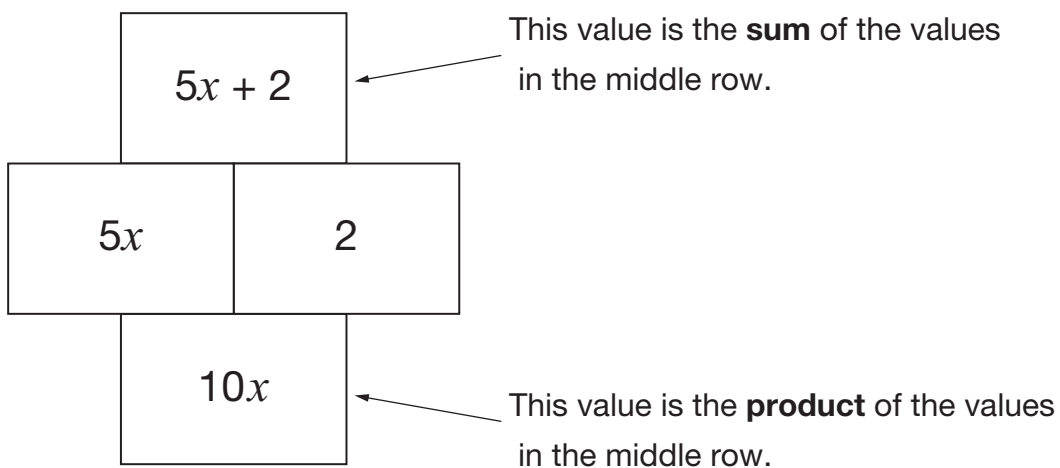

Use these rules to complete the algebra grids below.

Write your expressions as simply as possible.

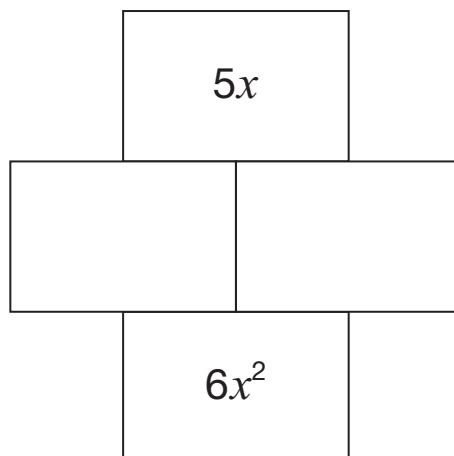
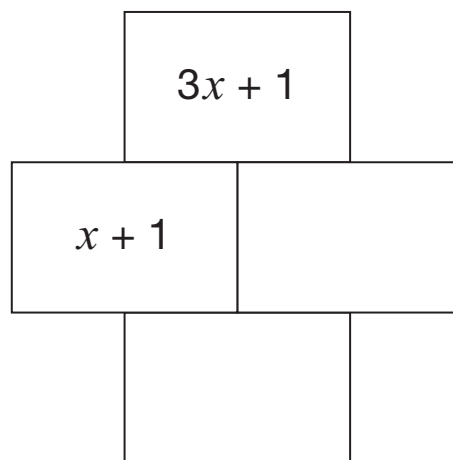
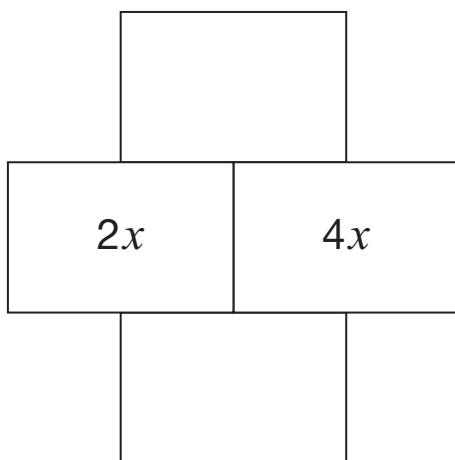

\_\_\_\_\_  
 \_\_\_\_\_  
 \_\_\_\_\_  
 3 marks

11. This shape is made of four congruent kites meeting at a point.

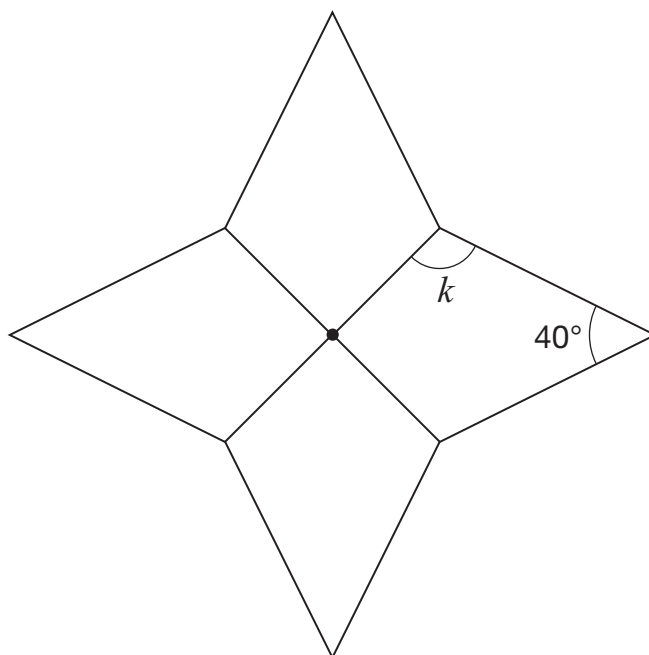

Not drawn accurately

Calculate the size of angle  $k$



$$k = \text{_____}^\circ$$

\_\_\_\_\_  
\_\_\_\_\_  
2 marks



12. Look at the diagram of a cuboid.

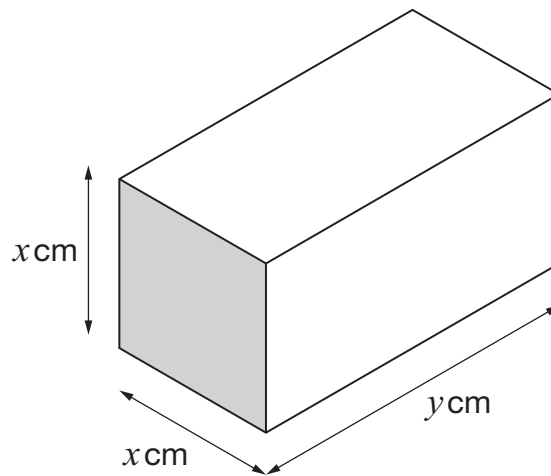

Not drawn accurately

The **volume** of the cuboid is  $100\text{cm}^3$

What could the values of  $x$  and  $y$  be?

Give **two** possible pairs of values.



$x =$  \_\_\_\_\_  $y =$  \_\_\_\_\_

\_\_\_\_\_ 1 mark

$x =$  \_\_\_\_\_  $y =$  \_\_\_\_\_

\_\_\_\_\_ 1 mark



13. A pupil wants to investigate a report that Belgian one euro coins are biased in favour of heads.

Here is her plan for the investigation.

I will spin **20** Belgian one euro coins to give one set of results.

I will do this **10 times** to give a total of **200 results** to work out an estimated probability of spinning a head.

If this probability is **greater than 56%** my conclusion will be that Belgian one euro coins are biased in favour of heads.

The table shows the 10 sets of results.

Number of each set of <b>20</b> coins that showed heads									
10	13	11	11	12	12	11	9	10	11

Using the pupil's plan, what should her conclusion be?

You **must** show your working.



2 marks



14. The diagram shows a shaded rectangle.  
It is divided into four smaller rectangles, labelled A, B, C and D.

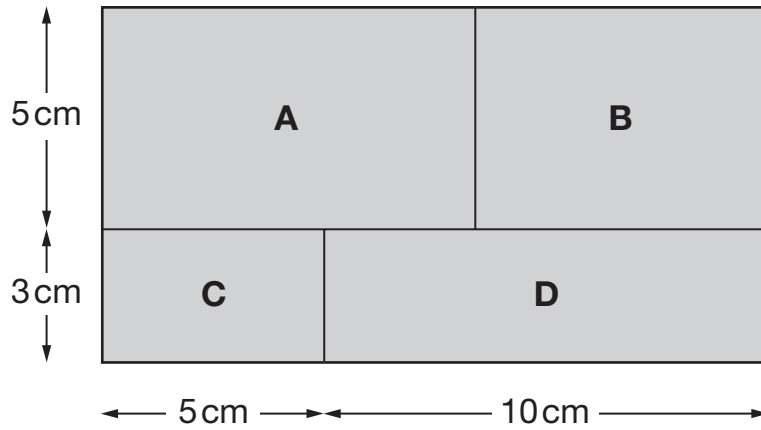

Not drawn accurately

The ratio of area **C** to area **B** is **1 : 2**

Calculate area A.



\_\_\_\_\_ cm<sup>2</sup>

\_\_\_\_\_

2 marks

15. Field voles are small animals that do not live for very long.  
A scientist recorded data on **1000** of these voles that were born on the same day.  
The graph shows how many voles were still alive after a number of weeks.

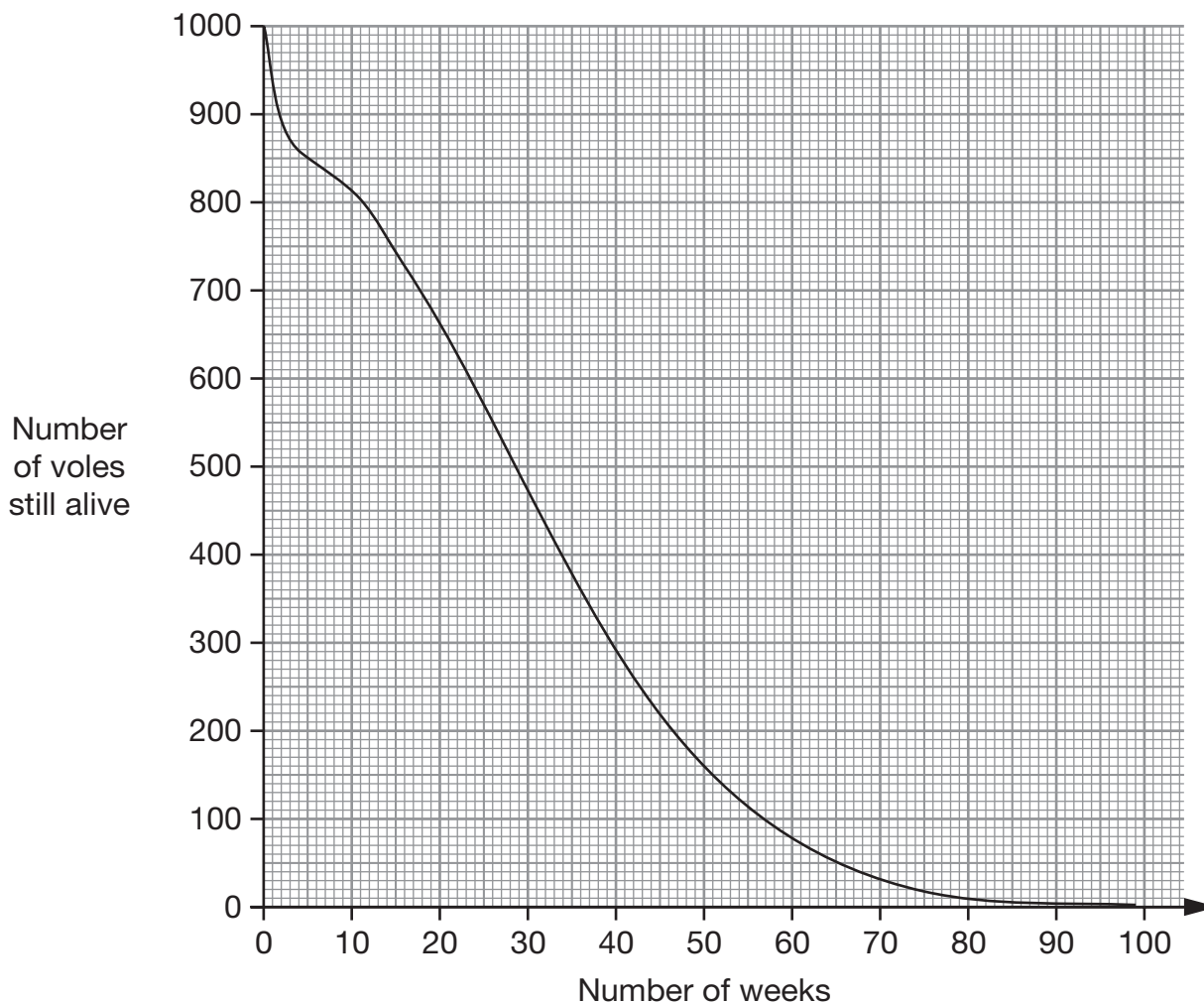

Use the graph to answer these questions.

- (a) Estimate the probability that a field vole will live to be **at least 20** weeks old.



\_\_\_\_\_

1 mark

- (b) A field vole is 40 weeks old.

Estimate the probability that it will live to be at least 50 weeks old.



\_\_\_\_\_

1 mark



16. Films at the cinema and films on television are shown at different speeds.

**Cinema**  
24 pictures per second

**Television**  
25 pictures per second

At the cinema a film lasts **175** minutes.

How many minutes does the same film last on television?



\_\_\_\_\_ minutes

\_\_\_\_\_  
2 marks

17. The graph shows the straight line with equation  $y = x + 1$
- This straight line passes through the point  $(0, 1)$

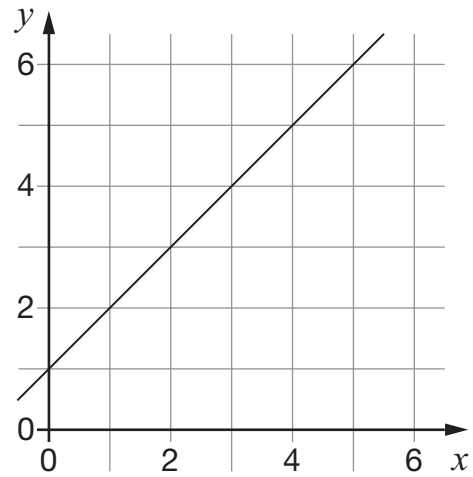

- (a) Write the equations of **two different straight lines** that also pass through the point  $(0, 1)$



\_\_\_\_\_ and \_\_\_\_\_

1 mark

1 mark

- (b) The straight line with equation  $x + y = 5$  is **perpendicular** to  $y = x + 1$

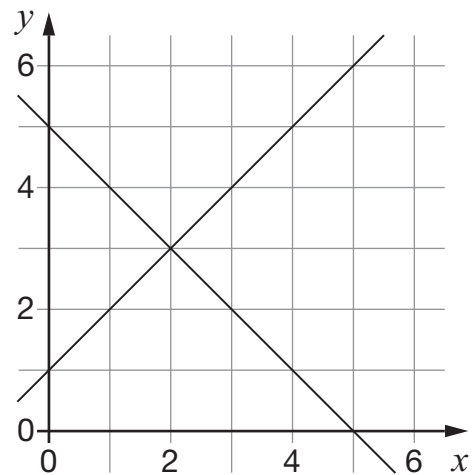

Write the equation of a **different straight line** that is also perpendicular to  $y = x + 1$



\_\_\_\_\_

1 mark



18. A housing report gave this information.

In the year 2001, the population of England was **49.87 million** people.

Most of these people lived in households.

The total number of households was **20.97 million**.

The average (mean) household size was **2.34 people**.

In the year 2001, what **percentage** of people in England did **not** live in households?

Give your answer to **1 decimal place**.



\_\_\_\_\_ %

\_\_\_\_\_  
\_\_\_\_\_  
3 marks

19. Six cubes **each** have a **surface area** of  $24\text{cm}^2$

They are joined together to make a cuboid.

What could the **surface area** of this cuboid be?

There are two different answers. Write them both.

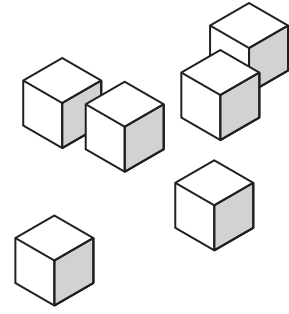

\_\_\_\_\_  $\text{cm}^2$  or \_\_\_\_\_  $\text{cm}^2$

2 marks



20. The diagram shows five points joined with four straight lines.

BC and AD are parallel.

BCE and ADE are isosceles triangles.

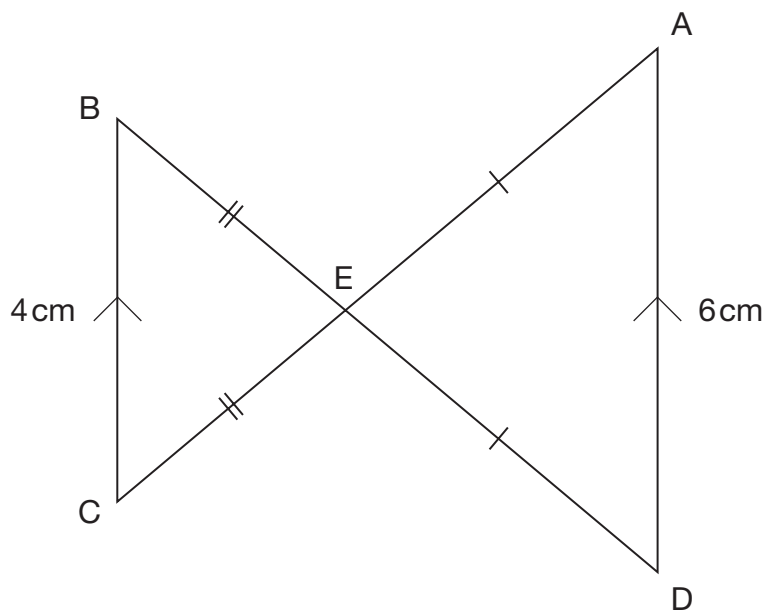

Not drawn accurately

The total length of the four straight lines is **40cm**.

What is the length of EA?



\_\_\_\_\_ cm

\_\_\_\_\_

\_\_\_\_\_

\_\_\_\_\_

3 marks



21. I have three fair dice, each numbered 1 to 6

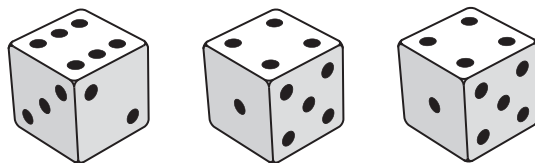

I am going to throw all three dice.

What is the probability that all three dice will show the **same** number?



2 marks



**22.** Since 1952 the total number of people living in Wales has **increased** by about **one eighth**.

The total number of people living in Wales now is about **3 million**.

About how many people lived in Wales in 1952?



\_\_\_\_\_ million \_\_\_\_\_  
2 marks

23. Engineers have worked on the leaning tower of Pisa to make it safe.

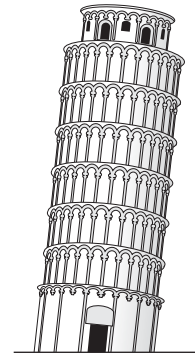

A website gave this information about the tower before the work.

The height of the tower is 56m.

The angle of tilt is  $5.5^\circ$

The tower leans 5.2m from the perpendicular.

Not drawn accurately

Give calculations to show that the information cannot all be true.



2 marks



**END OF TEST**